

G & H SERIES

MIL-C-26500 Hermetic connectors were developed for application where a controlled atmosphere such as inert gasses, partial vacuums, or constant environments are needed. These receptacles are designed for use in aerospace, electronic, electrical power, and control circuits.

The "G" & "H" Series receptacles are manufactured to American Micro Products, Inc. (AMPI / ACE) standards and meet the intermateability requirements of MIL-C-26500 types B and T respectively. They are hermetically sealed with an all glass seal to prevent air leakage in excess of 1×10^{-7} cc/sec of helium at one atmosphere.

The "G" series receptacles have a bayonet coupling mechanism and the "H" series have the threaded coupling type.

Standard hermetic receptacles are supplied with either solder cup or eyelet type contact terminations. Contacts for other applications such as thermocouple or flex prints are also available. Standard receptacles are steel shells with nickel-iron alloy contacts and a final coat of tin plate. Other materials and finishes can be supplied to meet specific application requirements. Both series are supplied with interfacial seals and O-rings.

ELECTRICAL SERVICE DATA

The maximum current to be carried by the connector, based on contact size, is the same as permitted by the wire bundle. Maximum current ratings and corresponding voltage drops under test condition, fully assembled, are shown below.

CONTACT SIZE	TEST CURRENT (AMPS)	POTENTIAL DROP (MILLIVOLTS)
20	5	100
16	10	95
12	17	95

PART NUMBER EXPLANATION

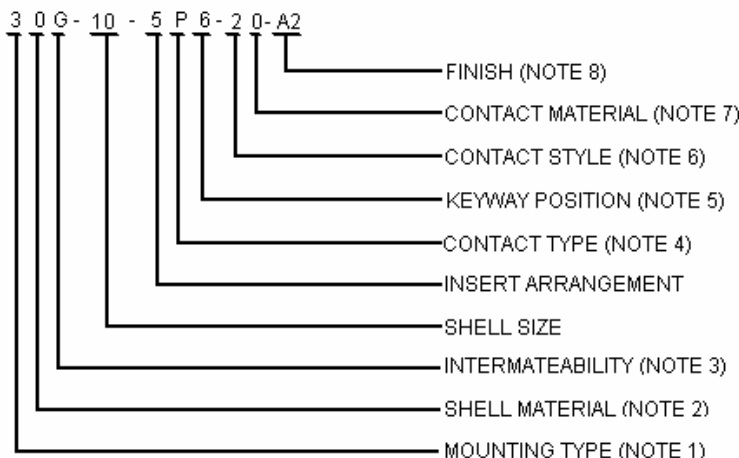

STANDARD MATERIALS AND FINISHES

SHELLS

Material: Cold rolled steel per ASTM 108
Finish: Fused tin per MIL-T-10727 over copper per MIL-C-14550 over nickel per QQ-N-290.

CONTACTS

Material: Nickel-iron alloy per MIL-I-23011, class 2.
Finish: Fused tin per MIL-T-10727 over copper per MIL-C-14550 over nickel per QQ-N-290.

BAYONET PINS

Material: Corrosion resistant steel per QQ-S-764, type 303.

INSERTS

Material: Glass

INTERFACIAL SEALS and "O" RINGS

Material: Fluorosilicone rubber.

BAYONET COUPLING		
DESCRIPTION	MILITARY DESIGNATION	AMPI DESIGNATION
JAM NUT MOUNT	MS24265H*B*CN	50G-*PN-20
	MS24265H*B*EN	50G-*PN-10
SOLDER MOUNT	MS27034H*B*CN	20G-*PN-20
	MS27034H*B*EN	20G-*PN-10
BOX MOUNT	CLASS H NOT SPECIFIED	30G-*PN-20
		30G-*PN-10
MATING PLUG	MS24266R*B*SN	
THREAD COUPLING		
JAM NUT MOUNT	MS24265H*T*CN	50H-*PN-20
	MS24265H*T*EN	50H-*PN-10
SOLDER MOUNT	MS27034H*T*CN	20H-*PN-20
	MS27034H*T*EN	20H-*PN-10
BOX MOUNT	CLASS H NOT SPECIFIED	30H-*PN-20
		30H-*PN-10
MATING PLUG	MS24266R*T*SN	

HIGH POTENTIAL TEST VOLTAGE

Unmated connectors tested per method 3001 of MIL-STD-1344 shall have a maximum leakage of 2 milliamperes and show no evidence of electrical breakdown of flashover.

SERVICE RATING	TEST VOLTAGE (RMS 60 CPS)
1	1500

NOTES:

1. -- 2--Circular flange solder mount
3--Square flange box mount
5--Jam nut mount
2. -- 0-- Ferrous alloy
1 thru 7- various stainless steel #303 thru #347
3. -- G--MIL-C-26500 type B intermateability
H-- MIL-C-26500 type T intermateability
4. -- P--Pin
5. -- Alternate keyway position
6. -- 1--Eyelet
2--Solder cup
7. -- 0--Nickel-iron alloy
8. -- A2--Fused tin over copper over nickel
M5--Tin contacts with shell passivated

INDEX OF INSERT ARRANGEMENTS MIL-STD-1554

SHELL SIZE	INSERT ARRANGEMENT	TOTAL CONTACTS	CONTACT SIZE				COAX
			22	20	16	12	
8	2	2	2				
	3	3	3				
	98	3	3				
10	2	2	2				
	5	5	5				
	20	2		2			
12	3	3		3			
	12	12	12				
14	4	4			4		
	7	7		7			
	15	15	15				
16	10	10		10			
	24	24	24				
18	14	14		14			
	31	31	31				
20	16	16		16			
	41	41	41				
22	19	19		19			
	55	55	55				
24	61	61	61				

ALL ARRANGEMENTS ARE SERVICE RATING I

KEYWAYS POSITION
FRONT FACE OF PIN INSERT SHOWN

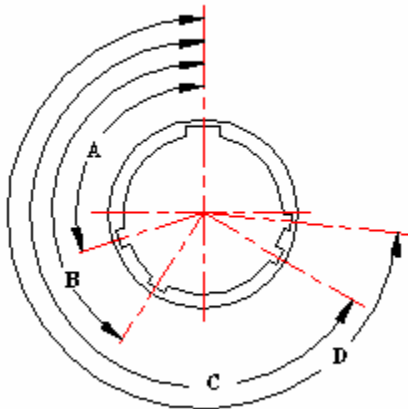

SHELL SIZE	KEYWAY POSITION	A°	B°	C°	D°
8 10	NORMAL	105	140	215	265
	6	102	132	248	320
	7	80	118	230	312
	8	35	140	205	275
	9	64	155	234	304
	Y	25	115	220	270
12 THRU 24	NORMAL	105	140	215	265
	6	18	149	192	259
	7	92	152	222	342
	8	84	152	204	334
	9	24	135	199	240
	Y	98	152	268	338

Y POSITION NOT AVAILABLE FOR SHELL SIZE 8

**SOLDER MOUNT
20G RECEPTACLES (REF. MS27034)**

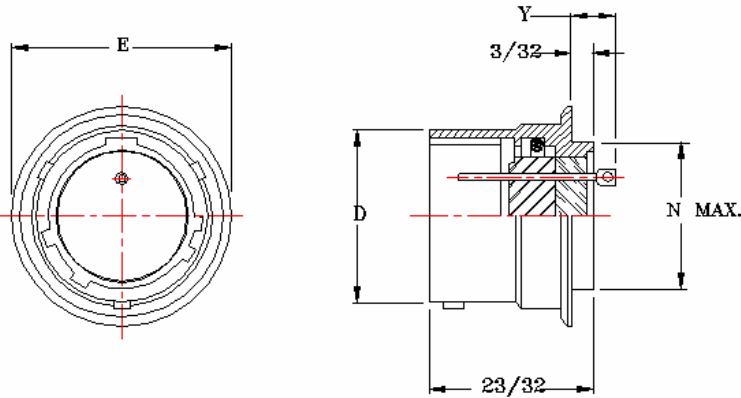

CONTACT SIZE	Y MAX
20	0.330
16	0.400
12	0.400

SHELL SIZE	PART NUMBER	D	E	N
		+000 -005	+020 -020	MAX
8	20G-8-(*P▼-(**)	0.536	0.705	0.437
10	20G-10-(*P▼-(**)	0.659	0.840	0.562
12	20G-12-(*P▼-(**)	0.829	1.045	0.750
14	20G-14-(*P▼-(**)	0.898	1.090	0.812
16	20G-16-(*P▼-(**)	1.025	1.210	0.937
18	20G-18-(*P▼-(**)	1.131	1.340	1.062
20	20G-20-(*P▼-(**)	1.256	1.475	1.182
22	20G-22-(*P▼-(**)	1.381	1.590	1.312
24	20G-24-(*P▼-(**)	1.506	1.725	1.432

▼ REPLACE WITH ALTERNATE INSERT POSITION INDICATOR /(*) PIN ARRANGEMENT
NORMAL POSITION INDICATOR REQUIRED IS N /(**) CONTACT STYLE AND MATERIAL

**BOX MOUNT
30G RECEPTACLES (REF. MS24264)**

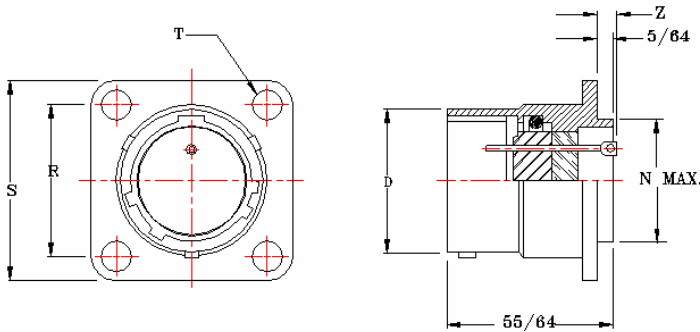

CONTACT SIZE	Z MAX	
	EYELET	SOLDER POT
20	0.109	0.150
16	0.171	0.210
12	0.220	0.220

SHELL SIZE	PART NUMBER	D	N	R	S	T
		+000 -005	MAX	+005 -005	+005 -005	+000 -009
8	30G-8-(*P▼-(**)	0.536	0.437	0.594	0.812	0.125
10	30G-10-(*P▼-(**)	0.659	0.562	0.719	0.937	
12	30G-12-(*P▼-(**)	0.829	0.750	0.812	1.031	
14	30G-14-(*P▼-(**)	0.898	0.812	0.906	1.125	
16	30G-16-(*P▼-(**)	1.025	0.937	0.969	1.250	
18	30G-18-(*P▼-(**)	1.131	1.062	1.062	1.343	
20	30G-20-(*P▼-(**)	1.256	1.182	1.156	1.437	
22	30G-22-(*P▼-(**)	1.381	1.312	1.250	1.562	0.154
24	30G-24-(*P▼-(**)	1.506	1.432	1.375	1.703	

▼ REPLACE WITH ALTERNATE INSERT POSITION INDICATOR /(*) PIN ARRANGEMENT
NORMAL POSITION INDICATOR REQUIRED IS N /(**) CONTACT STYLE AND MATERIAL

**JAM NUT MOUNT
50G RECEPTACLES (REF. MS24265)**

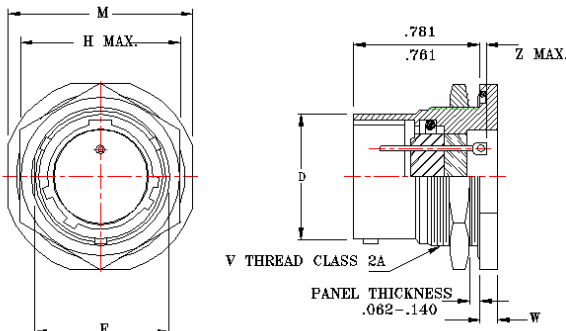

CONTACT SIZE	Z MAX
20	0.165
16	0.235
12	0.235

SHELL SIZE	PART NUMBER	D	F	H	M	V	W
		+000 -005	+003 -003	MAX	+005 -005	THREAD CLASS 2 A	+020 -020
8	50G-8-(*P▼-(**)	0.536	0.593	0.828	0.979	0.6250-20 UN	0.117
10	50G-10-(*P▼-(**)	0.659	0.718	0.953	1.104	0.7500-20 UNEF	
12	50G-12-(*P▼-(**)	0.829	0.905	1.140	1.291	0.9375-20 UNEF	
14	50G-14-(*P▼-(**)	0.898	0.968	1.250	1.391	1.0000-20 UNEF	
16	50G-16-(*P▼-(**)	1.025	1.093	1.329	1.516	1.1250-20 UN	
18	50G-18-(*P▼-(**)	1.131	1.217	1.455	1.641	1.2500-20 UN	
20	50G-20-(*P▼-(**)	1.256	1.342	1.642	1.766	1.3750-18 UNEF	
22	50G-22-(*P▼-(**)	1.381	1.467	1.705	1.954	1.5000-20 UN	0.148
24	50G-24-(*P▼-(**)	1.506	1.592	1.892	2.079	1.6250-18 UNEF	

▼ REPLACE WITH ALTERNATE INSERT POSITION INDICATOR /(*) PIN ARRANGEMENT
NORMAL POSITION INDICATOR REQUIRED IS N /(**) CONTACT STYLE AND MATERIAL